

# Perceived Supervisor Support Cure: Why and How to Retain and Reengage Seasonal Employees for the Next Season\*

Huseyin Arasli, Hasan Evrim Arici\*\*

## Abstract

The main purpose of this study is to develop and examine a research model that depicts ways to obtain engaged and embedded seasonal employees in the hospitality industry. The model also tests the mediating role of work engagement in the effect of supervisor support on seasonal employees' job embeddedness and turnover intention. Data were collected from a sample of seasonal employees working at 5-star hotels in Antalya, Turkey. The research model was developed utilizing structural equation modelling. The results demonstrate that supervisor support is key to boosting seasonal employees' work engagement, which in turn leads to increased job embeddedness and reduced turnover intention. The discussion section offers implications, limitations, and future directions for research.

*Keywords:* Hospitality management, supervisor support, work engagement, job embeddedness, seasonal employee retention, Turkey  
*JEL codes:* J53, J63, M12, O15, Z32

## Introduction

Seasonality is considered a crucial problem for the tourism industry and has been held responsible for creating many challenges for the industry (Butler 2001). The most crucial concern regarding seasonality is the difficulty of recruiting and retaining full-time staff (Andriotis 2005). The seasonal nature of tourism is one of the challenges to the EU's hospitality industry. According to data from Eurostat, the statistical office of the European Union, in 2011, virtually 40% of European citizens had their holiday between July and September (EUROSTAT 2015). Therefore, tourism companies mostly prefer to recruit seasonal employees during this period.

Previous studies have shown that since seasonality stigmatizes the tourism industry as an unstable source of employment, the industry is considered by employees to be insecure and unpromising in terms of future recruitment (Clinebell/Clinebell 2007; Ainsworth/Purss 2009). This condition leads to an in-

\* Received: 02.02.17, accepted: 19.11.17, 2 revisions.

\*\* *Huseyin Arasli* (Corresponding author), Ph.D., Prof., Faculty of Tourism, Eastern Mediterranean University, Turkey (North Cyprus). Email: huseyin.arasli@emu.edu.tr, araslih@gmail.com. Main research interests: leadership, quality management, human resource management, organizational behaviour, small and medium sized businesses, service and hospitality industry.

*Hasan Evrim Arici*, Dr., Eastern Mediterranean University, Turkey (north Cyprus). Email: hasanevrimarici@yahoo.com. Main research interests: leadership, human resource management, employee relations, and family firms.

crease in the turnover rate, which is a critical challenge for supervisors in the tourism industry (Guchait et al. 2015). According to Tracey and Hinkin (2008), the average turnover cost of front-desk staff was \$5.864, and turnover reduces revenue and increases costs in the tourism industry. Similarly, the turnover rate of hotel employees was found to range between 30 per cent and 59 per cent in research conducted in the major tourism regions of Turkey. The high turnover rate of Turkey's tourism industry ultimately results in higher costs and lower quality of customer service (Kuruüzüm et al. 2009). As indicated by the research, a high turnover rate is considered part of the culture and a characteristic of the Turkish tourism industry among Turkish hotel employees. In other words, hotel management accepts the high turnover rate as a characteristic of their work culture rather than trying to solve the problem. Additionally, the employee turnover rate is higher in hotels than in other service industries (DiPietro/Condly 2007), and this culture is claimed to be the most important statement of the high rate in turnover (Iverson/Deery 1997).

Supervisor support has been demonstrated to have a significant effect on reducing turnover intention, although not all empirical results have been in agreement (Firth et al. 2004). For instance, Kalliath and Beck (2001) found that supervisory support mitigated not only nurses' burnout symptoms but also directly and indirectly their turnover intention. A similar finding was indicated by Gentry et al. (2007), who tested the impact of supervisor support and unemployment rate on employee retention and proved that supervisor support leads to the retention of service employees. Nichols et al. (2016) also revealed that supervisor support was a significant predictor of turnover intention among front-line hospital employees. However, other studies have failed to reveal a strong association between supervisor support and employee turnover intention. Johnston et al. (1988), for instance, indicated that satisfaction with one's job, but not one's manager, was a significant predictor of intention to quit. Freddolino and Heaney (1992) also found that turnover intention was related to the existence of social undermining by co-workers rather than supervisors. Moreover, Tuzun and Kalemci (2012), in their empirical study of Turkey's insurance industry, found that participants who reported high perceived supervisor support (PSS) and low levels of perceived organizational support were more likely to report increased turnover intentions. Given the contradictory findings related to the relationship between PSS and turnover intention, this study examined the role of PSS on seasonal employees' turnover intention. Additionally, to our knowledge, no research has specifically focused on the effect of seasonal employees' PSS on their intention to leave the hospitality industry.

Organizations that want to be sustainable and successful over the long term must consider how to increase the number of qualified and engaged employees (Lu et al. 2014; Dhar 2015). Numerous scholars have attempted to study work engagement since it represents a significant aspect of work behaviour. Engaged workers

are energized and willing to give their maximum effort and concentrate on their job (Kahn 1990). However, the changing nature of work has generated an array of challenges for companies seeking to improve work environments to motivate workers to fully engage in their job (Swanberg et al. 2011). Whereas Boyce et al. (2007) claimed that temporary employees are more likely to demonstrate withdrawal and counterproductive behaviours and are less likely to engage in an organization, several studies have shown that supervisor support can provide more engaged hotel employees who are highly motivated in their work and become more embedded in their jobs (Swanberg et al. 2011; Karatepe/Ngeche 2012).

Hence, there is a need to study PSS to make hospitality jobs more attractive and to retain seasonal employees in the hospitality industry by increasing employees' work engagement and job embeddedness. In this sense, this study aims to examine the impact of PSS on seasonal employees' work engagement, job embeddedness and turnover intention.

Recognizing these gaps in the hospitality literature, the present study develops and suggests a study model delineating ways to achieve more engaged and embedded seasonal employees in the hospitality industry based on social exchange theory (SET) using data collected from seasonal employees working at 5-star hotels in Antalya, Turkey. The following section presents the theoretical background and research model. Afterwards, the hypothesized relationships are proposed, and the research methodology and results of the empirical study are discussed. The study concludes with managerial implications as well as limitations and avenues for future research.

## **Theoretical Background and Hypotheses**

### *Theory*

According to SET (Blau 1964), the employee and the organization can be viewed as two main "actors" in the social exchange relationship (Rousseau 1989; Settoon et al. 1996; Hofmann/Morgeson 1999). Social exchange has been conceptualized in the management literature in two main ways: (1) a global exchange relationship between subordinates and the employing organization and (2) a more focused, dyadic association between employees and their supervisors (Settoon et al. 1996; Wayne et al. 1997). At the global level, Eisenberger et al. (1986) proposed the concept of perceived organizational support (POS) to reflect the individual's evaluation of the organization's role in the exchange relationship. In other words, POS refers to global perception that the organization values the individual's contribution and cares about the individual's well-being (Eisenberger et al. 1986; Rhoades/Eisenberger 2002). In organizations, POS is provided via PSS, fairness, employee-organization relationship quality, human resource practices, and job conditions, such as job security and developmental

opportunities (Shore/Tetrick 1991; Wayne et al. 1997; Rhoades/Eisenberger 2002; Kurtessis et al. 2015). Among these, as the second means of social exchange, one of the most important is PSS. Employees generalize their exchange relationships from their supervisor to the organization because they view their supervisor's favourable or unfavourable orientation towards them as indicative of the organization's support (Eisenberger et al. 2002; Eisenberger et al. 2010; Eisenberger/Stinglhamber 2011; Eisenberger et al. 2014).

Research focusing on evaluations of support received from the supervisor has argued that the relationship between the employee and the organization is often enacted through relationships with representatives of the organization (e.g., supervisors) (Levinson 1965; Kottke/Sharafinski 1988). Supporting the view that PSS reflects the social exchange process, studies have shown that the support received from the supervisor as an indicator of organizational support is related more strongly to employees with a more vigorous exchange orientation (Eisenberger et al. 1986) and less strongly to employees who do not trust the organization to reciprocate (Lynch et al. 1999). Moreover, studies identifying a social exchange relationship with supervisory support (Kottke/Sharafinski 1988) have derived from that concept that benefits obtained from supervisors correspond with subordinates' own input in the exchange relationship (Kang et al. 2015). In sum, PSS is conceived as a social exchange construct since subordinates will remain in an organization if their supervisors appreciate the development and welfare of their employees and maintain good relationships with their employees based on reciprocal respect and recognition (Eisenberger et al. 2002).

A careful examination of the recent literature has underlined the importance of PSS to increasing employee-level outcomes, such as work engagement, organizational citizenship behaviour, organizational commitment, job satisfaction, and employee retention, based on SET (e.g., Liden/Graen 1980; Wayne/Green 1993; Babin/Boles 1996; Griffin et al. 2001; Eisenberger et al. 2002; Karatepe/Kilic 2007; DeConinck 2010; Kuvaas/Dysvik 2010; Eisenberger et al. 2014; Holland et al. 2016; Ling Suan/Mohd Nasurdin 2016).

Given the aforementioned discussion, we may conclude that hotel managers and supervisors promoting and caring about the contribution and welfare of their seasonal employees could send positive signals and encouragement to the employees under their supervision. When workers perceive satisfactory support needed from their supervisors, they are more apt to fulfil the requirements of the work, which in turn enhances work engagement (Kang et al. 2015), "a positive, fulfilling, work related state of mind that is characterized by vigour, dedication and absorption" (Schaufeli et al. 2002:74). In conclusion, seasonal employees will feel more "connected" to the company and will "return the favour" via distinct avenues, consisting of high retention levels (Gentry et al. 2007). Thus, a positive social exchange relationship between supervisors and their seasonal em-

employees is more likely to increase employees' job embeddedness (Karatepe 2014) and to reduce their turnover intention (Roderick/Deery 1997; Van Knippenberg et al. 2007).

## *Hypotheses*

### *PSS and Work Engagement*

A great deal of research has revealed that supervisor support has an important effect on organizational effectiveness across many industries (Thomas et al. 2005; Tourigny et al. 2005; Lu et al. 2013). However, how PSS influences the attitudinal and behavioural outcomes of seasonal employees in the hospitality industry has been disregarded in the hospitality literature even though such employees constitute a considerable proportion of the industry, composing nearly half of its ranks. PSS is described as the level to which workers feel their manager's or supervisor's support and the promotion of workers' performance and interests (Burke et al. 1992). A main contributor to an employee's performance and effectiveness is support from their manager or supervisor (Schaubroeck/Fink 1998). Pertinent to the present study, PSS is conceived as a social exchange construct, whereby workers can feel "the degree to which supervisors value their contributions and care about their well-being" (Eisenberger et al. 2002:565). In other words, employees having higher PSS may be more engaged in their work as a part of the reciprocity norm of SET to help the corporation reach its goals (Rhoades et al. 2001). Previous research also demonstrated that support from supervisors is likely to be a significant predictor of work engagement (Bakker et al. 2005; Salanova et al. 2005; Saks 2006; James et al. 2011). Hence, the first hypothesis of this study is as follows:

*Hypothesis 1: PSS is positively related to seasonal employees' work engagement.*

### *PSS and Job Embeddedness*

SET (Blau 1964) contends that the supervisor-follower association has a large impact on both individual and organizational outcomes (Wheeler et al. 2010). SET would argue that if supervisors demonstrate interest in their workers and concern for their workers' development, a reciprocal association might be shaped in such a way that the workers, especially those who do not feel connected to the hotel organization, may feel connected to and repay their supervisors and company (Gentry et al. 2007). Thus, PSS enables workers to meet the requirements of their roles more successfully (Karatepe 2014). Under these conditions, workers are less likely to quit their jobs and organizations, since they appreciate the advantages arising from the associations with their supervisors (Harris et al. 2011). The relationship between PSS and job embeddedness of front-

line hotel employees has been examined to a limited extent (e.g., Karatepe 2014). Given the impact of PSS on front-line hotel employees' job embeddedness, there is a need to develop the following hypothesis regarding job seasonality to determine whether the impact of PSS differentiates between front-line and seasonal employees.

*Hypothesis 2: PSS is positively related to seasonal employees' job embeddedness.*

### *PSS and Turnover Intention*

Turnover is so pervasive in today's hospitality organizations that managers looking for quick fixes too often ignore the issue and instead focus their efforts on those aspects of the job that reap more immediate rewards on the bottom line through such practices as yield management; thus, the employee turnover problem is considered insuperable (Stein 1989). Moreover, some studies have argued that the turnover of part-time and seasonal employees cannot be combatted, exacerbating the situation with expectations of low retention that lead to organization-wide dissatisfaction (Inman/Enz 1995). According to previous studies, the inefficacy of supervisor support is costly and shows its ugly face as employee turnover, absenteeism, and low performance, which in the long run can be extremely costly to the success of the hospitality organization (Lim/Boger 2005). Although many studies contend that employees quit jobs due to poor supervisors (Hinkin/Tracey 2000; Davidson/Wang 2011; Mohsin et al. 2013), there have been somewhat mixed empirical findings concerning the direct effect of PSS on intention to leave (Firth et al. 2004). For example, Moore (2001) revealed that PSS decreased nurses' burnout levels, which then decreased their intention to leave. However, Eisenberger et al. (2002) did not find a direct association between PSS and intention to quit. In their research on non-managerial workers at restaurants and hotels, Cho et al. (2009) also did not find a direct relationship between PSS and employee turnover intention. Therefore, Cho et al. (2009) called for more studies to identify the impact of PSS on turnover intention. To answer this invitation, the following hypothesis was developed:

*Hypothesis 3: PSS is negatively related to seasonal employees' turnover intention.*

### *Work Engagement and Job Embeddedness*

In accordance with Halbesleben and Wheeler (2008), engagement could change over time, since it is not particularly permanent. However, they contended that embeddedness might change more slowly, since more severe contexts would decrease job embeddedness. We assume that workers with sufficient resources in their work environment will be fully engaged with their job and highly embed-

ded in their work. Accordingly, Halbesleben and Wheeler (2008) discovered a positive relationship between work engagement and job embeddedness. Karatepe and Ngeche (2012) also contended that work engagement positively and significantly affected job embeddedness. In light of the empirical findings, we proposed the following hypothesis:

*Hypothesis 4: Work engagement is positively related to seasonal employees' job embeddedness.*

#### *Work Engagement and Turnover Intention*

Schaufeli and Bakker (2004) indicated that engaged workers are more likely to attach to their organizations and less likely to quit their jobs. According to SET, when two actors obey the exchange rules, a relationship between supervisor and employee, based on trust and loyalty as well as mutual commitments, will develop in an organization (Cropanzano/Mitchell 2005). Employees will become more engaged due to the mutual exchange. Ultimately, more engaged employees are more likely to maintain high-quality relationships with their supervisors based on respect and will show more favourable attitudes and intentions towards their organizations. Several studies have demonstrated work engagement to be positively related to intent to remain in the organization (Harter et al. 2002; Schaufeli/Bakker 2004; Jones/Harter 2005). Brunetto et al. (2012) also revealed that the path from employee engagement to turnover intention was negative and significant. More recently, Camgoz et al. (2016) explored high work engagement resulting in lower turnover intention among white-collar bank employees in Turkey. Because of the relationships demonstrated above, the following hypothesis was proposed:

*Hypothesis 5: Work engagement is negatively related to seasonal employees' turnover intention.*

#### *Mediating Effect of Work Engagement*

Such organizational benefits as productivity, customer satisfaction, and profitability derive from employee engagement (Jones/Harter 2005). Clearly, these organizational benefits could be obtained through employees' efforts, making worker retention a vital challenge for supervisors. A body of empirical findings suggests that the association between employee engagement and turnover intention relies in large part on the quality of the relationships between workers and their supervisors (Judge et al. 2001; Harter et al. 2002). However, various studies have examined the mediating effect of engagement on the relationship between antecedent variables and outcomes (Sonnentag 2003; Schaufeli/Bakker 2004). Sulea et al. (2012) explored the mediating impact of work engagement on the relationship between job characteristics and positive and negative extra role

behaviours. Biswas and Bhatnagar (2013) also contended that employee engagement is a mediator of the relationship of organizational support and person-organization fit with organizational commitment and job satisfaction. Moreover, in their study on retail sales workers, Eisenberger et al. (2002) explored an indirect relationship between supervisory support and turnover intention through organizational support, a crucial antecedent of organizational commitment. To our knowledge, the mediating role of work engagement between PSS and turnover intention has not yet been empirically tested among seasonal employees in the hospitality industry. Therefore, it is meaningful to analyse the indirect effect between supervisory support and turnover intention through work engagement.

*Hypothesis 6a: Work engagement mediates the negative impact of PSS on seasonal employees' turnover intentions.*

Whereas work engagement can change when job conditions alter, job embeddedness can change more slowly and will likely require more severe circumstances or “shocks” to decrease (Mitchell et al. 2001). Increasing work engagement has been a basic challenge for numerous businesses looking for avenues to contribute to employees' personal and institutional performance (Wong et al. 2010). Highly engaged followers work very hard because they have enhanced energy levels (Karatepe/Ngeche 2012). These workers are involved and engrossed in their work (Karatepe/Olugbade 2009; Bakker 2010). Previous empirical findings demonstrated that work engagement develops job embeddedness and, in particular, that workers remaining engaged in their work become embedded in their jobs (Karatepe/Ngeche 2012). Saks (2006) suggested that one of the most crucial antecedents of engagement is PSS. Zhang et al. (2008) also asserted that employees consider supervisor support as a significant exchange relationship; hence, consistent with SET, in return for supervisors' supportive efforts, workers feel the need to respond with effort and commitment. Therefore, there is a need to examine the indirect effect of supervisor support on job embeddedness by means of work engagement. This body of literature prompts the following hypothesis:

*Hypothesis 6b: Work engagement mediates the positive impact of PSS on seasonal employees' job embeddedness.*

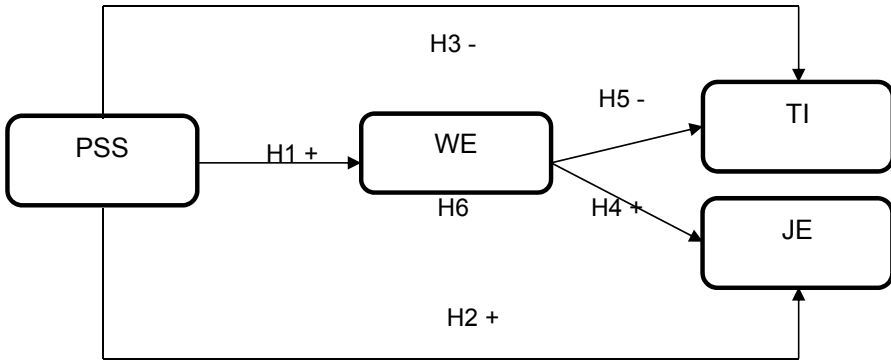
**Figure 1. Study model**

Note: PSS is perceived supervisor support, WE is work engagement, JE is job embeddedness, and TI is turnover intention.

## Methodology

### Sample and Procedure

The data were collected from 305 seasonal employees working in five-star hotels in Antalya, a destination where seasonality has an intense effect on Turkey's tourism industry. According to information obtained from the Antalya Provincial Directorate of Culture and Tourism at the time of the present study, approximately one third of the city's hotels were five-star facilities (304/911). These hotels also employ more seasonal employees based on their huge bed capacities and considering their payroll costs in comparison to other costs. Since the employees have a key role in the performance of the hotels and almost half of the employees are seasonal in Antalya's tourism industry (240 thousand) (AKTOB-Mediterranean Touristic Hoteliers Association 2014), their perceptions regarding the study variables have been targeted to investigate. The researchers chose seasonal employees of the five-star hotels as the focus of the study by utilizing the judgemental sampling method. A total of 25 five-star hotels agreed to take part in the research. The surveys were distributed to the participant employees in a meeting room supplied by the hotel managers. Before the questionnaires were distributed, the participants were assured that the information obtained from the respondents would be used only in this study and otherwise kept confidential. After being completed by the participants, the questionnaires were directly gathered by the research team. Among the 350 questionnaires distributed, 314 were collected individually in September 2016. The average return rate of the survey was high, at 89.7%, as a result of the hotel management providing the opportunity to collect data directly from their seasonal staffs. Nine questionnaires were biased and, thus, were excluded from the data evaluation process.

### *Questionnaire Design*

Regarding the measurement of Supervisor Support, researchers in studies by Karasek et al. (1982) and Kottke and Sharafinski (1988) used two of the effective measures, one of which is called the Survey of Perceived Supervisor Support (SPSS). The recent hospitality literature shows that Karatepe's 2014 study validated that of Karasek et al. (1982), which established one of the validated scales in the hospitality industry. The latter found that there was a positive relationship between supervisor support and job embeddedness for full-time hotel employees. Since the current model seeks to test whether the direct effect of PSS differentiates between full-time employees' and seasonal employees' job embeddedness, it was assumed that using the validated scale developed by Karasek et al. (1982) with five items would be reasonable for hotels in the research context. Additionally, nine items were adapted from the study of Schaufeli et al. (2006) to measure work engagement. Job embeddedness was measured with 6 items adapted from Crossley et al. (2007). To measure turnover intention, 3 items were taken from the study of Boshoff and Allen (2000). The respondents were asked to indicate their degree of agreement with each item on a five-point Likert scale, ranging from strongly disagree (1) to strongly agree (5). At the end of the questionnaire, five questions concerning the demographic characteristics of the seasonal employees were asked regarding gender, age, education, department, and organizational tenure (Table 2).

The survey items were originally prepared in English and then translated into Turkish using the back-translation method (McGorry 2000). One English translator and one Turkish language translator, fluent in written and spoken English, participated in the preparation of the survey items. Afterwards, two academicians with management and tourism backgrounds checked the questionnaire separately and gave their opinions regarding the phrasing and wording of the instrument. A preliminary study with a pilot sample of 25 seasonal employees in a 5-star hotel did not find any confusion with the wording or survey design.

### **Data Analysis**

The collected data were analysed using SPSS 21.0 (Statistical Package for the Social Sciences) and the AMOS (Analysis of Moment Structures) software package (Arbuckle 2005). The informants' profiles were created with the descriptive statistics, and the model hypotheses were examined with a Structural Equation Model (SEM). The dependence relationships were analysed by SEM simultaneously: This is useful particularly when one outcome variable is a predictor variable in dependence relationships (Hair et al. 1998).

**Table 1. Measurement parameter estimates<sup>a</sup>**

	Standardized Loading <sup>b</sup>	CCR	AVE
<b>PSS</b>		.85	.54
My supervisor encourages employees he/she supervises to develop new ways of doing things	.78		
My supervisor shows me how to improve my performance	.77		
My supervisor encourages employees he/she supervises to work as a team	.72		
My supervisor offers new ideas	.80		
My supervisor encourages employees he/she supervises to exchange opinions and ideas	.83		
<b>Work engagement</b>		.85	.54
At my work, I feel as though I am bursting with energy	.88		
At my job, I feel strong and vigorous	.85		
I am enthusiastic about my job	.82		
My job inspires me	.60		
When I get up in the morning, I feel like going to work	.62		
I feel happy when I am working intensely	.72		
I am proud of the work that I do	.88		
I am immersed in my work	.85		
I get carried away when I am working	.82		
<b>Turnover intention</b>		.98	.94
I often think about leaving this hotel	.96		
It would not take much to make me leave this hotel	.97		
I will probably be looking for another job soon	.97		
<b>Job embeddedness</b>		.87	.54
I feel attached to this hotel	.66		
It would be difficult for me to leave this hotel	.84		
I am too caught up in this hotel to leave	.74		
I feel tied to this hotel	.77		
I simply could not leave the hotel that I work for	.81		
I am tightly connected to this organization <sup>*</sup>	.85		

Note: CCR = composite construct reliability; AVE = average variance extracted.

a.  $\chi^2 = 536.29$ ,  $df = 218$ ,  $p < .01$ ; comparative fit index = .97; goodness-of-fit index = .87; Tucker-Lewis index = .96; root-mean-square error of approximation = .069; standardized root-mean-square residual = .132.

b. All loading values are significant at the 0.05 level.

SEM analysis can be conducted in two different manners: the one-step method and the two-step method. In conjunction with a one-step method, in which structural and measurement models are worked out simultaneously, the existence of interpretational confounding may not be detected, resulting in the fit being maximized at the rate of meaningful interpretability of the structures (Anderson/Gerbing 1988). A one-step analysis is helpful if there are a solid theoretical

background and an extremely reliable measure in the model (Hair et al. 1998). However, when the measures are not sufficiently reliable or a theory is indeterminate, investigators should consider a two-step approach. Because absolute presentation of the indicators' reliability is best achieved in two steps by avoiding the interaction of measurement and structural models (Hair et al. 1998), a two-step model was selected in the current study. In the first stage, the measurement model was first estimated and measured with a variety of fit indices. After the measurement model was adapted, the structural model was estimated in the second stage using the identical fit indices. Finally, the structural variables were scrutinized to determine whether the data verified the model hypotheses.

## Results

### *Respondents' Profiles*

The participants' demographic profiles are summarized in Table 2. The respondents comprised 190 women (62.3%) and 115 men (37.7%). The largest age group was below 34 years old (77.7%). Some 59 per cent of the participants had a bachelor's degree. Sixty-seven per cent of the respondents worked in the front office, whereas the rest worked in food and beverage departments. In terms of organizational tenure, approximately 19 per cent of the respondents had work experience of 1 season, 23 per cent had work experience of 2 seasons, some 40 per cent had work experience of 3 seasons, and the rest had more than three seasons of work experience in their current job.

### *Measurement Model*

First, Cronbach's alpha was utilized to check the reliability of all the constructs: perceived supervisor support, work engagement, job embeddedness, and turnover intention. All the coefficient alphas were greater than the commonly accepted cut-off level of .70 (Nunnally/Bernstein 1994; Table 1).

Afterwards, the measurement model was denoted to shape four latent variables with their barometers. Confirmatory factor analysis (CFA) demonstrated a good fit for the measurement model:  $\chi^2 = 536.29$ ;  $df = 218$ ;  $p < .01$ ; comparative fit index (CFI) = .97; goodness-of-fit index (GFI) = .87; Tucker-Lewis index (TLI) = .96; root-mean-square error of approximation (RMSEA) = .069; and standardized root-mean-square residual (RMR) = .132. All the indicators demonstrated important loading values on their denoted construct, and the standardized loadings were between .60 and .97 ( $p < .05$ ). All the constructs showed acceptable composite construct reliabilities (CCR) between .852 and .980.

**Table 2. Respondents' Profiles (n = 305)**

	Frequency	Percentage
<b>Gender</b>		
Female	190	62.3
Male	115	37.7
Total	305	100.0
<b>Age</b>		
18-24	116	38.0
25-34	121	39.7
35-44	64	21.0
45-54	3	1.0
55 or older	1	.3
Total	305	100.0
<b>Education</b>		
High school	89	29.2
Bachelor's degree	179	58.7
Master's degree	36	11.8
PhD	1	.3
Total	305	100.0
<b>Department</b>		
Front office	203	66.6
Food & beverage	102	33.4
Total	305	100.0
<b>Organizational tenure</b>		
1 season	59	19.3
2 seasons	71	23.3
3 seasons	121	39.7
4 seasons	39	12.8
More than 4 seasons	15	4.9
Total	305	100.0

The average variance extracted (AVE) indicates the amount of variance held by a construct in connection with the variance resulting from the random measurement error. The AVE scores of the constructs were between .54 and .94, which exceeded the .50 threshold value suggested by Fornell/Larcker (1981). The same authors also noted that if the composite reliability is higher than .60, the convergent validity is acceptable. Thus, we concluded that our measurement model has sufficient convergent validity.

**Table 3. Correlation Matrix**

Construct	Means	SD	1	2	3	4	5	6	7	8	9
1. Gender	1.38	0.49	—								
2. Age	1.86	0.80	-.007	—							
3. Education	1.83	0.63	.142*	.299**	—						
4. Department	1.33	0.47	.065	-.049	-.221**	—					
5. Organizational tenure	2.61	1.09	-.192**	.223**	.038	-.179**	—				
6. Perceived supervisor support	3.51	1.07	-.077	.015	-.015	.056	-.148**	—			
7. Work engagement	3.64	1.09	.172**	-.244**	.114*	.044	-.044	.235**	—		
8. Turnover intention	1.78	0.75	-.063	.060	-.060	.065	.017	-.227**	-.017*	—	
9. Job embeddedness	4.11	0.78	-.041	.064	.058	-.021	.090	.250**	.116*	-.191**	—

Note: SD denotes standard deviation. Gender was coded as a binary variable (0 = female and 1 = male). Age and organizational tenure were measured using a five-point scale, whereas education was measured using a four-point scale. Higher scores indicate older age, more education, and longer tenure. Department was coded as 1 = front-office, 2 = food and beverage.

\*  $p < .05$ . \*\*  $p < .01$ .

Discriminant validity exists when the ratio of the AVE in every construct goes beyond the square of the correlation coefficient with other factors. It demonstrates that each construct shares greater variance with its indicators than with other constructs. Two variables with a high correlation were job embeddedness and PSS ( $\Phi = .250$ ). However, the AVE in job embeddedness (.540) and PSS (.541) was more than the square of the correlation between the two constructs ( $\Phi^2 = .063$ ). Other variables that needed further investigation were PSS and work engagement ( $\Phi = .235$ ). The AVE in the factors (.541 for PSS and .542 for work engagement) exceeded the square of the correlation between the two constructs ( $\Phi^2 = .055$ ). Hence, we determined that all four factors possessed discriminant validity (Table 1).

The correlations, means, and standard deviations are presented in Table 3. Following the suggestion of Rhoades and Eisenberger (2002), we included demographic variables (i.e., gender, age, education, department, and organizational tenure) in the correlation analysis to examine the extent of their relationships, particularly with PSS, and their utility as control variables. As observed in Table 3, only organizational tenure had a significant and negative effect on PSS ( $r = -.148$ ,  $p < .01$ ). The correlation results also showed that work engagement had a significant and positive relationship with gender ( $r = .172$ ,  $p < .01$ ), age ( $r = .244$ ,  $p < .01$ ), and education ( $r = .114$ ,  $p < .05$ ).

### *Structural Equation Model*

As in the correlation analysis, the path analysis results showed that organizational tenure had a significant and negative effect on PSS. That is, more experienced seasonal employees in their current jobs needed less supervisor support. Furthermore, this finding is distinct from the correlation results in that a significant effect of education on work engagement could not be found in the path analysis, whereas gender and age still had significant positive effects on work engagement (Table 4). According to the findings, male and older seasonal employees were more engaged in their work. The rest of the control variables did not exert any significant effects on the study variables.

The study hypotheses were examined based on the significance of the structural path coefficients (Table 4). The path from PSS to work engagement was significant and positive, as expected. A significant negative association was found between PSS and turnover intention.

In line with our expectation, the path from PSS to job embeddedness was significantly positive. Finally, whereas a significant positive relationship was found between work engagement and job embeddedness, there was a significant negative relationship between work engagement and turnover intention, as proposed in the study model. Hence, H1 (PSS to work engagement:  $\gamma = .235$ ,  $p < .01$ ), H2 (PSS to job embeddedness:  $\gamma = .223$ ,  $p < .01$ ), H3 (PSS to turnover inten-

**Table 4. Breakdown of Total Effect of Research Model**

Independent Variables	Dependent Variables	Total Effect	Direct Effect	Indirect Effect
PSS	WE	.235**	.235**	.000
WE	TI	-.017*	-.017*	.000
WE	JE	.116**	.116**	.000
PSS	TI	-.227**	-.223**	-.004
PSS	JE	.250**	.223**	.027
Control Variables				
Org. Tenure	PSS	-.145** ( $t = -2.612$ )		
Age	WE	.321*** ( $t = 4.247$ )		
Gender	WE	.425*** ( $t = 3.538$ )		
Education	WE	.034 ( $t = 0.353$ )		

Note: PSS is perceived supervisor support; WE is work engagement; TI is turnover intention; and JE is job embeddedness.

\*  $p < .05$ . \*\*  $p < .01$ , \*\*\*  $p < .001$ .

tion:  $\gamma = -.223$ ,  $p < .01$ ), H4 (work engagement to job embeddedness:  $\gamma = .116$ ,  $p < .01$ ), and H5 (work engagement to turnover intention:  $\gamma = -.017$ ,  $p < .05$ ) were supported. Moreover, the unstandardized indirect effects of PSS on job embeddedness ( $\gamma = .027$ ) and turnover intention ( $\gamma = -.004$ ) were insignificant. The findings demonstrate that work engagement does not mediate the effects of PSS on job embeddedness and turnover intention. Hence, H6 (a) and H6 (b) were rejected.

## Discussion

### *Uniqueness of the Study*

Based on SET, the present study proposed and examined a research model analysing the effects of PSS on seasonal employees' job embeddedness and turnover intention as well as the mediating role of work engagement between the variables using data collected from 305 seasonal hotel employees. Since the empirical analyses proved that supervisor support has a strong effect on seasonal employees' job embeddedness and turnover intention without examining work engagement as a mediator, the study model has valuable implications for both scholars and industry professionals. This research uniquely contributes to the tourism and hospitality management literature in three ways.

First, because there have been mixed results regarding the effect of perceived supervisor support on employee turnover intention in the literature (e.g., Firth et al. 2004), this study has attempted to clarify this relationship through data collected from seasonal hotel employees. In this sense, PSS appeared as one of the key factors in reducing employee turnover intention based on the guidelines provided by SET.

The second unique feature of this research relates to the study sample. Although it has been suggested that current management theories must consider the differences between seasonal and permanent employees (Lee/Johnson 1991), to date, many studies have taken all employees into account as the same workforce, regardless of their status as seasonal or permanent, which is a common research mistake (Clinebell/Clinebell 2007). Specifically, the current knowledge regarding the study variables has been derived from previous empirical research focusing on full-time hotel employees in the hospitality industry. To extend the existing knowledge, there is a need for more empirical studies analysing data gathered from seasonal employees because a seasonal employee on average works 7-8 months of the year when tourism is at its peak. Additionally, as previously noted, nearly half of European citizens take their vacations during the summer period, which has caused the employment rate to double in countries such as Turkey, Italy, and Spain. Therefore, this paper contributes to the tourism and hospitality management literature by choosing seasonal employees as the study sample to examine the impact of PSS on both job embeddedness and turnover intention. Finally, the management findings of the current study could be used to motivate and retain seasonal employees in hotel organizations.

### *Evaluation of Findings*

As is well known in the hospitality literature, two of the largest problems are the turnover and embeddedness of valuable employees (Tracey/Hinkin 2008; Karatepe 2013). To date, many studies have been conducted to identify solutions to the turnover problem since it has costs, such as low morale, disrupted service, increased replacement and recruitment costs, and reduced profitability (e.g., Huselid 1995; Tracey & Hinkin, 2008; Karatepe 2014), for hospitality organizations. During the high season, with tourists' escalated needs and expectations, retaining promising employees, including seasonal, is also critical. More important, most likely, is embedding employees in these job settings, which means reducing the aforementioned turnover problem, attaching and committing employees to the organization, continuously delivering quality service, and achieving high profits, growth, and a better image in meeting changing visitors' needs and expectations. One of the possible strategies is the direct usage of supervisor support to mitigate turnover intention and enhance job embeddedness. Another is the engagement of employees via supervisors to achieve both outcomes. However, within the hospitality literature, some empirical studies have not found a direct association between PSS and turnover intention, suggesting that more studies need to be conducted (Eisenberger 2002; Cho et al. 2009). To develop this area of study, the current paper investigated and found a direct impact of PSS on seasonal workers' turnover intention. Thus, it adds to the hospitality management literature on the association between PSS and turnover intention, illuminating the somewhat complicated results.

However, this study assumes that PSS is an antecedent of work engagement. The result of this study is congruent with the empirical findings of previous studies, which showed a positive relationship between PSS and work engagement (Saks 2006; Swanberg et al. 2011). Additionally, in line with the studies of Karatepe (2013; 2014) and Nichols et al. (2016) on front-line employees in the hospitality and healthcare industries, the results show that PSS boosts seasonal employees' job embeddedness. This important result is consistent with SET—that subordinates with social support reciprocate to the corporation through job embeddedness.

The findings of this study also show that work engagement enhances seasonal employees' job embeddedness and mitigates their turnover intention, in line with the studies of Jones and Harter (2005) and Halbesleben and Wheeler (2008). This result suggests that more engaged seasonal employees are more embedded in their work and more likely to remain in the organization.

Additionally, the findings demonstrate that work engagement does not mediate the effects of PSS on seasonal employees' job embeddedness and turnover intention. Support from supervisors directly ensures a high level of job embeddedness, which leads to high intention to remain within the organization without the mediating effect of work engagement, as some authors claim (Halbesleben/Wheeler 2008; Karatepe/Ngeche 2012). Under these circumstances, PSS is one of the key factors boosting job embeddedness and mitigating turnover intention. Overall, it is plausible that supervisor support is a cure to difficulties in inspiring and retaining seasonal employees in the hospitality industry.

The demographic results indicated that fifty-nine per cent of the seasonal employees had a higher education degree and that these employees mainly held front-line jobs in the 5-star hotels in Antalya. This finding was not particularly interesting since, as in many other countries around the world, unemployment is one of the largest problems in Turkey due to the rapid expansion of higher education (Özoğlu et al. 2016), and seasonal jobs at five-star hotels attract university graduates seeking work experience in a multi-cultural environment. Another reason may be that the management of these hotels selects better-educated people to maintain certain standards of service, especially in their front-line positions. For example, recent research by Collins (2007: 80) supported this notion, stating, "The five-star hotels surveyed had a more highly educated group of personnel: 24 per cent had an elementary school education, 38 per cent were high-school graduates and 38 per cent had higher education degrees". In short, due to the shortage of jobs and the need to accumulate sufficient experience in a multi-cultural environment and provide financial assistance to their families, university graduates may prefer to work in such organizations during the high season. Additionally, five-star hotels' intention to keep their service standards high during the high season may be a point of intersection for both parties.

However, contrary to the explanation of Ng and Sorensen (2008; 262) that “high-tenure employees may still need supervisor support for overcoming some problems”, the findings of the present study indicated that seasonal employees who had more work experience in their current hotel organization needed less supervisor support. Moreover, the results indicated that control variables such as gender and age have significant effects on work engagement. That is, male and older employees feel more engaged than other seasonal employees. This is an important finding because many studies have found no or very low significance in the relationships between age and work engagement as well as gender and work engagement (e.g., Schaufeli et al. 2006; Garg 2014). The finding that older and male employees feel more engaged may be attributed to the fact that as age increases, seasonal male employees learn how to adapt themselves to the intensive work environment, and once they do so, they, in turn, become energetic, feel devoted, enjoy serving and are less conscious of time passing. The other reason may be the existing paternalistic system, as Aycan (2001) stated, where top management exhibits a parental approach, since paternalism is part of the organizational culture in Turkey. That is, hotel management seeks to provide job opportunities to seasonal employees and thereby economically contributes to families in the society, where there is a high unemployment rate (Tatoglu et al. 2002); in turn, especially older and male employees may show commitment, devotion, energy and compliance to their organizations as reciprocation of the benefits provided for them or their families.

### *Managerial Implications*

The findings of this study suggest some important managerial implications for hoteliers, who are intensely exposed to the seasonality effect and high turnover rate in the hospitality industry. First, because this study uncovered the crucial role of supervisor support as an important determinant of seasonal employees’ work engagement, it is vital that a supportive hospitality setting where seasonal employees can receive the necessary support from their supervisors be achieved and maintained. In line with SET, caring and concern related to PSS produce a feeling of obligation on the part of seasonal employees, who reciprocate with greater levels of work engagement. In other words, because previous studies defined seasonal employees as being less motivated and less engaged than permanent employees (Ainsworth/Purss 2009), hotel managers or supervisors should provide necessary support to these employees in the forms of empowerment, appraisal, development, compensation, training, etc., to obtain more engaged seasonal employees (Saks 2006). Otherwise, these employees may exhibit lower levels of work engagement than permanent employees due to the insufficient support received from their supervisors.

Second, the results of this study suggest that longer-tenure seasonal employees need less supervisor support than shorter-tenure employees in that supervisor support may be less important in determining the more experienced seasonal employees' work attitudes (e.g., job satisfaction). That is, as organizational tenure increases, one becomes more qualified in terms of improved psychological defences to combat environmental changes and work pressures (Ng/Sorensen 2008). Thus, supervisors should pay more attention to providing sufficient support particularly to shorter-tenure seasonal employees in coping with challenges such as role ambiguity, work stress, and low performance in hotel organizations.

Third, the findings suggest that hotel organizations can mitigate the turnover intentions of seasonal employees by increasing their PSS. For hotel organizations, developing supervisor support could be a relatively inexpensive and practical measure compared to costly alternatives such as rewards, pay increases, promotions, and training. In the hospitality setting, PSS can cover up the defects of organizational policies and senior management decisions that seem unsupportive and can keep turnover intention from increasing (Maertz et al. 2007). Therefore, hotel organizations should stimulate their supervisors to be more effective in developing themselves as a main source of support in the workplace, which will in turn bring about both developed POS and mitigated turnover intention directly.

Fourth, this study suggests that PSS is crucial to improving seasonal employees' job embeddedness. Given the significance of embedded subordinates, hotel managers or supervisors can effectively use social networking technology to draw seasonal employees into the hotel organization's network (Hinkin/Tracey 2010). Social media provide the possibility of virtually connecting seasonal employees, even if they are in scattered locations, particularly during the low season. Social networking technology can maintain seasonal employees' feelings of support from their supervisor even in the low season.

Finally, hotel organizations may further enhance seasonal employees' feelings of organizational support through following the abovementioned suggestions associated with supervisor support since seasonal employees may perceive the support given by their supervisors as an indicator of their organization's support (Eisenberger et al. 2002). However, hotel management must rigorously consider that commitment to the supervisor translates to commitment to the organization only as long as the seasonal employees observe their supervisor as somewhat committed to the organization (Maertz/Griffeth 2004). That is, special commitment to supervisors may even enhance turnover intention when a loyalty-inspiring supervisor quits the organization (Maertz et al. 2003). Thus, a programme of training and rewarding supervisors who are personally psychologically committed to the hotel organization for being supportive and for representing the organization as supportive merits consideration as a way to mitigate seasonal employees' turnover intention (Maertz et al. 2007).

## Limitations and Future Research Directions

There are some limitations of this study. First, it may still be constrained by common method bias because the data were collected from a single source, although the threat of this bias affecting the study results has been significantly mitigated by confirmatory factor analysis.

Second, although this study used the back-translation method, which has been described as one of the most reliable translation processes (McGorry 2000), issues of literal translation and missing information may still have arisen.

Third, the data were collected only from seasonal employees working in five-star hotels in Antalya, Turkey. Further studies that include seasonal employees working in three- and four-star hotels in Antalya as well as in other eastern and western European countries are imperative to provide a better comprehension of the generalizability and restricting circumstances of our proposed model. Future investigations should also develop a cross-cultural measure of the validity of the study model. Specifically, it would also be beneficial to examine the influence of the economic environment on employee turnover intention because an employee can easily change employers in a good socio-economic environment, which provides plenty of job opportunities, whereas he or she may think twice about doing so if the economic situation is unfavourable, which is currently the case of the Turkish tourism industry. Thus, we suggest further exploration in this area.

Fourth, in our study, seasonal employees were considered as a single workforce, not considering different subgroups. Similar data gathering may be conducted by dividing seasonal employees into relevant subgroups (e.g., Lundberg et al. 2009) to give us a better understanding of the moderating effects of these subgroups on the relationships among the study variables.

Fifth, given that jobs in the hospitality industry have been considered by seasonal employees as not contributing to their career development (Lee-Ross 1998), the examination of the moderating role of High-Performance Work Practices, such as internal promotion and career opportunities, on the relationship between PSS and seasonal employees' intention to remain would pay dividends.

Finally, this study concentrated only on PSS as an antecedent of seasonal employees' work engagement. Thus, the effects of the other antecedents, such as job characteristics and organizational support, should be explored in future studies.

## References

- Ainsworth, S./Purss, A. (2009): Same time, next year?, in: *Personnel Review*, 38, 3, 217-235.
- AKTOB (Mediterranean Touristic Hoteliers Association) (2014): A hundred-years of tourism in Turkey towards 2023. Retrieved from <http://www.aktob.org.tr/pdf/arastirma2014.pdf>.

- Anderson, J.C./Gerbing, D.W. (1988): Structural modeling in practice: A review and recommended two-step approach, in: *Psychological Bulletin*, 103, 411-423.
- Andriotis, K. (2005): Seasonality in Crete: Problem or a way of life?, in: *Tourism Economics*, 11, 2, 207-227.
- Antalya Provincial Directorate of Culture and Tourism. (2016). Tourism statistics. Retrieved from <http://www.antalyakulturturizm.gov.tr/TR,175821/konaklama-tesisi-istatistikleri.html>
- Arbuckle, J.L. (2005): *Amos 6.0 user's guide*. Chicago, IL: SPSS.
- Aycan, Z. (2001): Human resource management in Turkey: Current issues and future challenges, in: *International Journal of Manpower*, 22, 3, 252-260.
- Babin, B.J./Boles, J.S. (1996): The effects of perceived co-worker involvement and supervisor support on service provider role stress, performance and job satisfaction, in: *Journal of Retailing*, 72, 1, 57-75.
- Bakker, A.B. (2010): Engagement and "job crafting": Engaged employees create their own great place to work, in Albrecht, S.L. (ed.): *Handbook of employee engagement: Perspectives, issues, research and practice*, Cheltenham: Edward Elgar Publishing, 229-244.
- Bakker, A.B./Demerouti, E./Euwema, M.C. (2005): Job resources buffer the impact of job demands on burnout, in: *Journal of Occupational Health Psychology*, 10, 170-180.
- Boshoff, C./Allen, J. (2000): The influence of selected antecedents on frontline staff's perceptions of service recovery performance, in: *International Journal of Service Industry Management*, 11, 1, 63-90
- Biswas, S./Bhatnagar, J. (2013): Mediator analysis of employee engagement: Role of perceived organizational support, PO fit, organizational commitment and job satisfaction, in: *Vikalpa*, 38, 1, 27-40.
- Blau, P. (1964): *Exchange and Power in Social Life*. New York: Wiley.
- Boyce, A.S./Ryan, A.M./Imus, A.L./Morgeson, F.P. (2007): Temporary worker, permanent loser? A model of the stigmatization of temporary workers, in: *Journal of Management*, 33, 1, 5-29.
- Brunetto, Y./Teo, S.T./Shacklock, K./Farr-Wharton, R. (2012): Emotional intelligence, job satisfaction, well-being and engagement: Explaining organisational commitment and turnover intentions in policing, in: *Human Resource Management Journal*, 22, 4, 428-441.
- Burke, M.J./Borucki, C.C./Hurley, A.E. (1992): Reconceptualizing psychological climate in a retail service environment: A multiple-stakeholder perspective, in: *Journal of Applied Psychology*, 77, 5, 717-729.
- Butler, R.W. (2001): Seasonality in tourism: Issues and implications, in: Baum, T./Lundtorpe, S. (eds.): *Seasonality in tourism*, Oxford: Pergamon, 5-22.
- Camgoz, S.M./Ekmekci, O.T./Karapinar, P.B./Guler, B.K. (2016): Job insecurity and turnover intentions: Gender differences and the mediating role of work engagement, in: *Sex Roles*, 75, 11, 583-598.
- Cho, S./Johanson, M.M./Guchait, P. (2009): Employees intent to leave: A comparison of determinants of intent to leave versus intent to stay, in: *International Journal of Hospitality Management*, 28, 3, 374-381.
- Clinebell, S.K./Clinebell, J.M. (2007): Differences between part-time and full-time employees in the financial services industry, in: *Journal of Leadership & Organizational Studies*, 14, 2, 157-167.

- Collins, A.B. (2007): Human resources: A hidden advantage?, in: *International Journal of Contemporary Hospitality Management*, 19, 1, 78-84.
- Cropanzano, R./Mitchell, M.S. (2005): Social exchange theory: An interdisciplinary review, in: *Journal of Management*, 31, 874-900.
- Crossley, C.D./Bennett, R.J./Jex, S.M./Burnfield, J.L. (2007): Development of a global measure of job embeddedness and integration into a traditional model of voluntary turnover, in: *Journal of Applied Psychology*, 92, 1031-1042.
- Davidson, M.C./Wang, Y. (2011): Sustainable labor practices? Hotel human resource managers views on turnover and skill shortages, in: *Journal of Human Resources in Hospitality & Tourism*, 10, 3, 235-253.
- DeConinck, J.B. (2010): The effect of organizational justice, perceived organizational support, and perceived supervisor support on marketing employees' level of trust, in: *Journal of Business Research*, 63, 12, 1349-1355.
- Dhar, R.L. (2015): Service quality and the training of employees: The mediating role of organizational commitment, in: *Tourism Management*, 46, 419-430.
- DiPietro, R.B./Condly, S.J. (2007): Employee turnover in the hospitality industry: An analysis based on the CANE model of motivation, in: *Journal of Human Resources in Hospitality & Tourism*, 6, 1-22.
- Eisenberger, R./Huntington, R./Hutchison, S./Sowa, D. (1986): Perceived organizational support, in: *Journal of Applied Psychology*, 71, 500-507.
- Eisenberger, R./Karagonlar, G./Stinglhamber, F./Neves, P./Becker, T.E./Gonzalez-Morales, M.G./Steiger-Mueller, M. (2010): Leader-member exchange and affective organizational commitment: The contribution of supervisor's organizational embodiment, in: *Journal of Applied Psychology*, 95, 6, 1085-1103.
- Eisenberger, R./Shoss, M.K./Karagonlar, G./Gonzalez-Morales, M.G./Wickham, R.E./Buffardi, L.C. (2014): The supervisor POS-LMX-subordinate POS chain: Moderation by reciprocation wariness and supervisor's organizational embodiment, in: *Journal of Organizational Behavior*, 35, 5, 635-656.
- Eisenberger, R./Stinglhamber, F. (2011): *Perceived Organizational Support: Fostering Enthusiastic and Productive Employees*. Washington, DC: American Psychological Association.
- Eisenberger, R./Stinglhamber, F./Vandenbergh, C./Sucharski, I.L./Rhoades, L. (2002): Perceived supervisor support: Contributions to perceived organizational support and employee retention, in: *Journal of Applied Psychology*, 87, 565-73.
- Eurostat (2015): Participation in tourism: 1996-2011. Retrieved from <http://ec.europa.eu/eurostat/web/tourism/data/main-tables>.
- Firth, L./Mellor, D.J./Moore, K.A./Loquet, C. (2004): How can managers reduce employee intention to quit?, in: *Journal of Managerial Psychology*, 19, 2, 170-187.
- Fornell, C./Larcker, D.F. (1981): Evaluating structure equation models with unobservable variables and measurement error, in: *Journal of Marketing Research*, 18, 39-50.
- Freddolino, P.P./Heaney, C.A. (1992): Staffing issues in group homes for people labelled mentally ill: An empirical investigation of job satisfaction and intention to quit, in: *Adult Residential Care Journal*, 6, 115-129.
- Garg, N. (2014): Employee Engagement and Individual Differences: A Study in Indian Context, in: *Management Studies and Economic Systems (MSES)*, 1, 1, 41-50.

- Gentry, W.A./Kuhnert, K.W./Mondore, S.P./Page, E.E. (2007): The influence of supervisory-support climate and unemployment rate on part-time employee retention: A multilevel analysis, in: *Journal of Management Development*, 26, 10, 1005-1022.
- Griffin, M.A./Patterson, M.G./West, M.A. (2001): Job satisfaction and teamwork: The role of supervisor support, in: *Journal of Organizational Behavior*, 22, 5, 537-550.
- Guchait, P./Cho, S./Meurs, J.A. (2015): Psychological contracts, perceived organizational and supervisor support: Investigating the impact on intent to leave among hospitality employees in India, in: *Journal of Human Resources in Hospitality & Tourism*, 14, 3, 290-315.
- Hair, J.F./Anderson, R.E./Tatham, R.L./Black, W.C. (1998): *Multivariate data Analysis* (5th ed.). Upper Saddle River, NJ: Prentice Hall.
- Halbesleben, J.R.B./Wheeler, A.R. (2008): The relative roles of engagement and embeddedness in predicting job performance and intention to leave, in: *Work and Stress*, 22, 242-256.
- Harris, K.J./Wheeler, A.R./Kacmar, K.M. (2011): The mediating role of organizational job embeddedness in the LMX outcomes relationship, in: *The Leadership Quarterly*, 22, 2, 271-281.
- Harter, J.K./Schmidt, F.L./Hayes, T.L. (2002): Business-unit-level relationship between employee satisfaction, employee engagement, and business outcomes: A meta-analysis, in: *Journal of Applied Psychology*, 87, 268-279.
- Hinkin, T.R./Tracey, J.B. (2000): The cost of turnover, in: *Cornell Hospitality Quarterly*, 41, 3, 14-21.
- Hinkin, T.R./Tracey, J.B. (2010): What makes it so great? An analysis of human resources practices among Fortune's best companies to work for, in: *Cornell Hospitality Quarterly*, 51, 2, 158-70.
- Hofmann, D.A./Morgeson, F.P. (1999): Safety-related behavior as a social exchange: The role of perceived organizational support and leader-member exchange, in: *Journal of Applied Psychology*, 84, 286-96.
- Holland, P./Cooper, B./Sheehan, C. (2016): Employee voice, supervisor support, and engagement: The mediating role of trust, in: *Human Resource Management*, DOI:10.1002/hrm.21809.
- Huselid, M.A. (1995): The impact of human resource management practices on turnover, productivity, and corporate financial performance, in: *Academy of Management Journal*, 38, 3, 635-672.
- Inman, C./Enz, C. (1995): Shattering the myths of the part-time worker, in: *Cornell Hotel and Restaurant Administration Quarterly*, 36, 5, 70-73.
- Iverson, R.D./Deery, M. (1997): Turnover culture in the hospitality industry, in: *Human Resource Management Journal*, 7, 71-83.
- James, J./McKechnie, S.P./Swanberg, J. (2011): Predicting employee engagement in an age-diverse retail workforce, in: *Journal of Organizational Behavior*, 32, 173-196.
- Johnston, M.W./Parasuraman, A./Futrell, C.M./Sager, J. (1988): Performance and job satisfaction effects on salesperson turnover: A replication and extension, in: *Journal of Business Research*, 16, 1, 67-83.
- Jones, J.R./Harter, J.K. (2005): Race effects on the employee engagement-turnover intention relationship, in: *Journal of Leadership & Organizational Studies*, 11, 2, 78-88.

- Judge, T.A./Thoresen, C.J./Bono, J.E./Patton, G.K. (2001): The job satisfaction job performance relationship: A qualitative and quantitative review, in: *Psychological Bulletin*, 127, 376-407.
- Kahn, W. (1990): Psychological conditions of personal engagement and disengagement at work, in: *Academy of Management Journal*, 33, 4, 692-724.
- Kalliath, T.J./Beck, A. (2001): Is the path to burnout and turnover paved by a lack of supervisory support: A structural equations test, in: *New Zealand Journal of Psychology*, 30, 2, 72-78.
- Kang, H.J./Gatling, A./Kim, J. (2015): The impact of supervisory support on organizational commitment, career satisfaction, and turnover intention for hospitality frontline employees, in: *Journal of Human Resources in Hospitality & Tourism*, 14, 1, 68-89.
- Karasek, R.A./Triantis, K.P./Chaudhry, S.S. (1982): Coworker and supervisor support as moderators of associations between task characteristics and mental strain, in: *Journal of Occupational Behavior*, 3, 2, 181-200.
- Karatepe, O.M. (2013): High-performance work practices, work social support and their effects on job embeddedness and turnover intentions, in: *International Journal of Contemporary Hospitality Management*, 25, 6, 903-921.
- Karatepe, O.M. (2014): The importance of supervisor support for effective hotel employees: An empirical investigation in Cameroon, in: *Cornell Hospitality Quarterly*, 55, 4, 388-397.
- Karatepe, O.M./Kilic, H. (2007): Relationships of supervisor support and conflicts in the work-family interface with the selected job outcomes of frontline employees, in: *Tourism management*, 28, 1, 238-252.
- Karatepe, O.M./Ngeche, R.N. (2012): Does job embeddedness mediate the effect of work engagement on job outcomes? A study of hotel employees in Cameroon, in: *Journal of Hospitality Marketing & Management*, 21, 4, 440-461.
- Karatepe, O.M./Olugbade, O.A. (2009): The effects of job and personal resources on hotel employees' work engagement, in: *International Journal of Hospitality Management*, 28, 504-512.
- Kottke, J.L./Sharafinski, C.E. (1988): Measuring perceived supervisory and organizational support, in: *Educational and Psychological Measurement*, 48, 4, 1075-1079.
- Kurtessis, J.N./Eisenberger, R./Ford, M.T./Buffardi, L.C./Stewart, K.A./Adis, C.S. (2015): Perceived organizational support a meta-analytic evaluation of organizational support theory, in: *Journal of Management*, 1-31, DOI: 10.1177/0149206315575554.
- Kuruüzüm, A./Ipekçi Ç.E./Irmak, S. (2009): Path analysis of organizational commitment, job involvement and job satisfaction in Turkish hospitality industry, in *Tourism review*, 64, 1, 4-16.
- Kuvaas, B./Dysvik, A. (2010): Exploring alternative relationships between perceived investment in employee development, perceived supervisor support and employee outcomes, in: *Human Resource Management Journal*, 20, 2, 138-156.
- Lee-Ross, D. (1998): The reliability and rationale of Hackman and Oldham's job diagnostic survey and job characteristics model among seasonal hotel workers, in: *International Journal of Hospitality Management*, 17, 4, 391-406.
- Lee, T.W./Johnson, D.R. (1991): The effects of work schedule and employment status on the organizational commitment and job satisfaction of full versus part-time employees, in: *Journal of Vocational Behavior*, 38, 208-224.

- Levinson, H. (1965): Reciprocation: The relationship between man and organization, in: *Administrative Science Quarterly*, 9, 370-390.
- Liden, R.C./Graen, G. (1980): Generalizability of the vertical dyad linkage model of leadership, in: *Academy of Management Journal*, 23, 3, 451-465.
- Ling Suan, C./Mohd Nasurdin, A. (2016): Supervisor support and work engagement of hotel employees in Malaysia: Is it different for men and women?, in: *Gender in Management: An International Journal*, 31, 1, 2-18.
- Lim, E./Boger, E. (2005): Management requires leadership, in: *Consortium Journal of Hospitality & Tourism*, 9, 59-66.
- Lu, C.Q./Wang, H.J./Lu, J.J./Du, D.Y./Bakker, A.B. (2014): Does work engagement increase person-job fit? The role of job crafting and job insecurity, in: *Journal of Vocational Behavior*, 84, 2, 142-152.
- Lu, L./Cooper, C.L./Lin, H.Y. (2013): A cross-cultural examination of presenteeism and supervisory support, in: *Career Development International*, 18, 5, 440-456.
- Lundberg, C./Gudmundson, A./Andersson, T.D. (2009): Herzberg's Two-Factor Theory of work motivation tested empirically on seasonal workers in hospitality and tourism, in: *Tourism Management*, 30, 6, 890-899.
- Lynch, P.D./Eisenberger, R./Armeli, S. (1999): Perceived organizational support: Inferior versus superior performance by wary employees, in: *Journal of Applied Psychology*, 84, 4, 467-483.
- Maertz, C.P./Griffeth, R.W. (2004): Eight motivational forces and voluntary turnover: A theoretical synthesis with implications for research, in: *Journal of Management*, 30, 5, 667-683.
- Maertz, C.P./Griffeth, R.W./Campbell, N.S./Allen, D.G. (2007): The effects of perceived organizational support and perceived supervisor support on employee turnover, in: *Journal of Organizational Behavior*, 28, 8, 1059-1075.
- Maertz, C.P./Stevens, M.J./Campion, M.A. (2003): A turnover model for the Mexican maquiladoras, in: *Journal of Vocational Behavior*, 63, 1, 111-135.
- McGorry, S.Y. (2000): Measurement in a cross-cultural environment: Survey translation issues, in: *Qualitative Market Research: An International Journal*, 3, 2, 74-81.
- Mitchell, T.R./Holtom, B.C./Lee, T.W./Sablinski, C.J./Erez, M. (2001): Why people stay: Using job embeddedness to predict voluntary turnover, in: *Academy of Management Journal*, 44, 1102-1121.
- Mohsin, A./Lengler, J./Kumar, B. (2013): Exploring the antecedents of intentions to leave the job: The case of luxury hotel staff, in: *International Journal of Hospitality Management*, 35, 48-58.
- Moore, K.A. (2001): Hospital restructuring: Impact on nurses mediated by social support and a perception of challenge, in: *Journal of Health and Human Services Administration*, 23, 4, 490-517.
- Ng, T.W.H./Sorensen, K.L. (2008): Toward a further understanding of the relationships between perceptions of support and work attitudes. A meta-analysis, in: *Group & Organization Management*, 33, 3, 243-268.
- Nichols, H.M./Swanberg, J.E./Bright, C.L. (2016): How does supervisor support influence turnover intent among frontline hospital workers? The mediating role of affective commitment, in: *The Health Care Manager*, 35, 3, 266-279.

- Özoğlu, M./Gür, B.S./Gümüş, S. (2016): Rapid expansion of higher education in Turkey: The challenges of recently established public universities (2006–2013), in: *Higher Education Policy*, 29, 1, 21-39.
- Rhoades, L./Eisenberger, R. (2002): Perceived organizational support: A review of the literature, in: *Journal of Applied Psychology*, 87, 4, 698-714.
- Rhoades, L./Eisenberger, R./Armeli, S. (2001): Affective commitment to the organization: The contribution of perceived organizational support, in: *Journal of Applied Psychology*, 86, 825-36.
- Roderick, D.I./Deery, M. (1997): Turnover culture in the hospitality industry, in: *Human Resource Management Journal*, 7, 4, 71-82.
- Rousseau, D.M. (1989): Psychological and implied contracts in organizations, in: *Employee Rights and Responsibilities Journal*, 2, 121-139.
- Saks, A. (2006): Antecedents and consequences of employee engagement, in: *Journal of Managerial Psychology*, 21, 7, 600-619.
- Salanova, M./Agut, S./Peiró, J.M. (2005): Linking organizational resources and work engagement to employee performance and customer loyalty: The mediating role of service climate, in: *The Journal of Applied Psychology*, 90, 1217-1227.
- Schaubroeck, J./Fink, L.S. (1998): Facilitating and inhibiting effects of job control and social support on stress outcomes and role behavior: A contingency model, in: *Journal of Organizational Behavior*, 19, 2, 167-195.
- Schaufeli, W.B./Bakker, A.B. (2004): Job demands, job resources, and their relationship with burnout and engagement: A multi-sample study, in: *Journal of Organizational Behavior*, 25, 293-315.
- Schaufeli, W.B./Bakker, A.B./Salanova, M. (2006): The measurement of work engagement with a short questionnaire: A cross-national study, in: *Educational and Psychological Measurement*, 66, 4, 701-716.
- Schaufeli, W.B./Salanova, M./González-Romá, V./Bakker, A.B. (2002): The measurement of engagement and burnout: A two sample confirmatory factor analytic approach, in: *Journal of Happiness Studies*, 3, 1, 71-92.
- Settoon, R.P./Bennett, N./Liden, R.C. (1996): Social exchange in organizations: Perceived organizational support, leader-member exchange, and employee reciprocity, in: *Journal of Applied Psychology*, 81, 3, 219-227.
- Shore, L.M./Tetrick, L.E. (1991): A construct validity study of the survey of perceived organizational support, in: *Journal of Applied Psychology*, 76, 5, 637-643.
- Sonnentag, S. (2003): Recovery, work engagement, and proactive behavior: A new look at the interface between nonwork and work, in: *Journal of Applied Psychology*, 88, 3, 518-528.
- Stein, J.C. (1989): Efficient capital markets, inefficient firms: A model of myopic corporate behavior, in: *The Quarterly Journal of Economics*, 104, 4, 655-669.
- Sulea, C./Virga, D./Maricutoiu, L.P./Schaufeli, W./Dumitru, C.Z./Sava, F.A. (2012): Work engagement as mediator between job characteristics and positive and negative extra-role behaviors, in: *Career Development International*, 17, 3, 188-207.
- Swanberg, J.E./McKechnie, S.P./Ojha, M.U./James, J.B. (2011): Schedule control, supervisor support and work engagement: A winning combination for workers in hourly jobs?, in: *Journal of Vocational Behavior*, 79, 3, 613-624.

- Tatoglu, E./Erdal, F./Ozgun, H./Azakli, S. (2002): Resident attitudes toward tourism impacts: The case of Kusadasi in Turkey, in: *International Journal of Hospitality & Tourism Administration*, 3, 3, 79-100.
- Thomas, J.L./Bliese, P.D./Jex, S.M. (2005): Interpersonal conflict and organizational commitment: Examining two levels of supervisory support as multilevel moderators, in: *Journal of Applied Social Psychology*, 35, 11, 2375-2398.
- Tourigny, L./Baba, V.V./Lituchy, T.R. (2005): Job burnout among airline employees in Japan: A study of the buffering effects of absence and supervisory support, in: *International Journal of Cross Cultural Management*, 5, 67-85.
- Tracey, J.B./Hinkin, T.R. (2008): Contextual factors and cost profiles associated with employee turnover, in: *Cornell Hospitality Quarterly*, 49, 1, 12-27.
- Tuzun, I.K./Kalemci, R.A. (2012): Organizational and supervisory support in relation to employee turnover intentions, in: *Journal of Managerial Psychology*, 27, 5, 518-534.
- Van Knippenberg, D./Van Dick, R./Tavares, S. (2007): Social identity and social exchange: Identification, support, and withdrawal from the job, in: *Journal of Applied Social Psychology*, 37, 3, 457-477.
- Viswesvaran, C./Sanchez, J.I./Fisher, J. (1999): The role of social support in the process of work stress: A meta-analysis, in: *Journal of Vocational Behavior*, 54, 314-334.
- Wayne, S.J./Green, S.A. (1993): The effects of leader-member exchange on employee citizenship and impression management behavior, in *Human Relations*, 46, 12, 1431-1440.
- Wayne, S.J./Shore, L.M./Liden, R.C. (1997): Perceived organizational support and leader-member exchange: A social exchange perspective, in: *Academy of Management Journal*, 40, 1, 82-111.
- Wheeler, A.R./Harris, K.J./Harvey, P. (2010): Moderating and mediating the HRM effectiveness-Intent to turnover relationship: The roles of supervisors and job embeddedness, in: *Journal of Managerial Issues*, 22, 2, 182-196.
- Wong, C.A./Laschinger, H.K.S./Cummings, G.G. (2010): Authentic leadership and nurses' voice behaviour and perceptions of care quality, in: *Journal of Nursing Management*, 18, 8, 889-900.
- Zhang, A./Tsui, A.S./Song, L.J./Li, C./Jia, L. (2008): How do I trust thee? The employee-organization relationship, supervisory support, and middle manager trust in the organization, in: *Human Resource Management*, 47, 1, 111-132.